

INTER-MIX AUTOMATIC RECORD CHANGER---Part No. 35-1176

SPECIFICATIONS

PHILCO INTER-MIX RECORD CHANGER, Part No. 35-1176 plays and automatically changes with one loading—14 ten-inch and twelve-inch records mixed together in any order. This record changer will also separately play 15 ten-inch records or 13-twelve inch records. In addition, the mechanism is designed to operate with slightly warped records.

Service information contained in this bulletin covers operation, care, and adjustments that may be necessary if the mechanism ceases to function properly.

When ordering parts, refer to the part number of the entire mechanism in addition to the number and name of parts shown in the figures of this bulletin.

PHILCO RECORD PLAYER NEEDLES

To obtain brilliant life-like tone quality, PHILCO Record Player Needles are recommended. These needles are especially designed to give high fidelity tone reproduction—less record wear and less surface noise. One needle plays 15 to 20 records. The use of inferior needles in the pick-up of this mechanism will greatly affect the tone reproduction performance.

AUTOMATIC AND MANUAL POSITIONS

A control knob (1) Fig. 2 is provided for placing the mechanism in the automatic or manual operating position.

When changing from manual to automatic or automatic to manual positions, the mechanism should be turned off and allowed to complete its cycle. The knob can then be set for the position desired as follows:

To operate the mechanism manually, press knob (1) Fig. 2 marked "Press-Turn" down and turn to the right (clockwise) until record support arm assembly (16) Fig. 1 is in the extreme clockwise position.

For the automatic operating position, control knob (1) Fig. 2 is turned to the left (counter-clockwise) until knob snaps up.

PICK-UP DOES NOT INDEX PROPERLY ON OUTER EDGE OF 10" AND 12" RECORDS

The pick-up is set for 12" records by the trip cam (15) Fig. 1 that is pivotally mounted under the selector blade on main record support post (12) Fig. 1. This trip cam is operated by the edge of a 12" record compressing the cam when the record support arm moves in a clockwise direction. This cam moves trip lever blade (14) Fig. 1 and toggle bar and spring (38) Fig. 3 which pushes set lever blade (5) Fig. 3 into position to hold the tone arm locator (36) Fig. 3 in the 12" position.

After playing a record or the mechanism has been rejected, the set lever (5) Fig. 3 is reset for the 10" position by the control cam bracket lever (35) Fig. 3 mounted on the set lever shaft. The control cam bracket (35) Fig. 3 engages the control shaft cam pin (31) Fig. 3 at the start of rotation.

Adjustment of the tone arm when placing the needle in the first groove of 10" and 12" records is controlled by tone arm locator (36) Fig. 3. When 10" or 12" adjustments are made, the 12" adjustment should be made first. If 10" adjustment alone is necessary, the 12" adjustment should be re-checked. Adjustment of the locator lever is as follows:

12-inch Record Adjustment

1. Turn control knob (1) Fig. 2 to "manual" position.
2. Place a 12" record on the turntable.
3. Start mechanism and allow pick-up to position itself on the outer edge of the record. If the needle has not been placed in the center of the smooth outer rim of the record, adjust stop (2) Fig. 3 by loosening set screw. Move the stop in the direction necessary to center the needle on the smooth outer rim of the record.

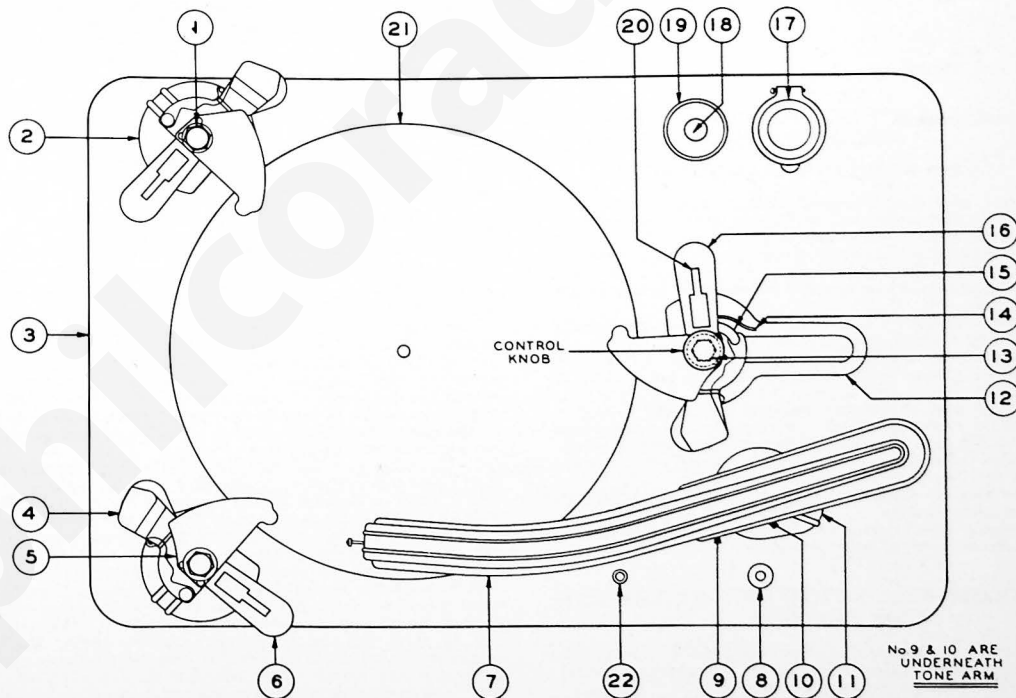

TOP VIEW OF RECORD CHANGER PART No. 35-1176

FIGURE 1

INTER-MIX AUTOMATIC RECORD CHANGER---Part No. 35-1176

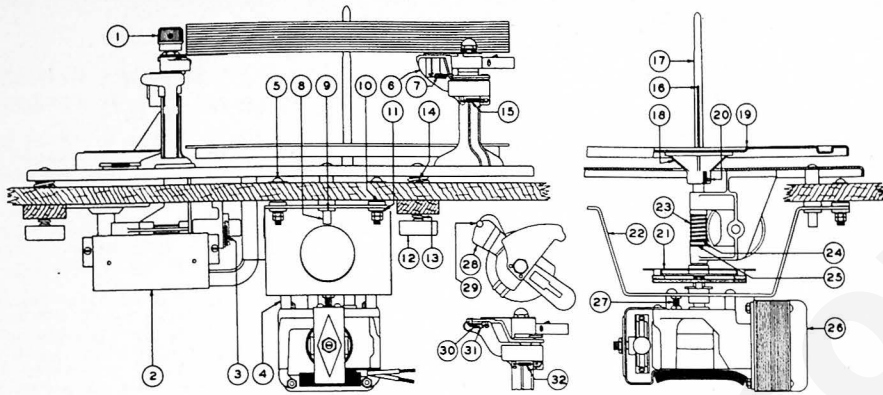

SIDE VIEW OF RECORD CHANGER PART No. 35-1176 & MOTOR PART No. 35-1177
FIGURE 2

10-inch Record Adjustment

1. Set control knob (1) Fig. 2 to "automatic" position.
2. Load the mechanism with several 10" records.
3. Allow mechanism to set a record on turntable and place the pick-up on the smooth outer rim of the record.
4. If the pick-up does not come down in the center of the smooth outer edge of the record, adjust the following:
5. Loosen 10" record stop (1) Fig. 3.
6. Move the stop slightly toward or away from the stop pin as the case may be to center the pick-up needle on the outer edge of the record.

If, after making the above adjustments, it is found that the pick-up will not move into the first groove after the needle is centered on the outer edge of the record, examine the following parts:

1. Spring (2) Fig. 3 on 12" adjustment stop may be weak.
2. Tone arm lever or swivel shaft may be binding; examine and lubricate.

TONE ARM ELECTRIC REJECT SWITCH WILL NOT OPERATE

(When no record is on turntable)

The tone arm electric reject switch operates when the mechanism is first loaded and no records are on the turntable or no records are on the record support arms. This switch closes when the pick-up needle drops into a groove provided in the turntable; allowing the tone arm to go to a lower level and causing switch contact to close. Adjustment of this switch is as follows:

1. Adjust screw (9) Fig. 1 located in the tone arm directly above the end of the tone arm shaft. Turn this screw in the direction necessary to obtain a clearance of $\frac{1}{16}$ " between the bottom of the groove in the turntable and the bottom end of the needle.
2. With a record on the turntable and the needle resting on the record, a clearance of $\frac{1}{16}$ " between the top and bottom contacts of the tone arm electric reject switch should be obtained. Bend the moving contacts spring upward or downward to obtain the necessary clearance.
3. Also check the electric magnet (19) Fig. 3 and associated wiring for open circuits.
4. Check the small metal rod connecting the trip trigger (13) Fig. 3 and lever of electric magnet.

MECHANISM WILL NOT REJECT AT THE END OF RECORDS

The tone arm is designed to reject records with an oscillating or spiral reject groove. To make the adjustments for either type of records, proceed as follows:

1. See that the screw (10) Fig. 1 which clamps the tone arm swivel bracket is tight. Make sure that the set screws holding the tone arm lever (12) Fig. 3 to the tone arm shaft are tight.

2. Oscillating Groove Records

Records with an oscillating reject groove are rejected by the trip dog located on the end of the tone arm lever (12) Fig. 3 engaging the saw teeth of the trip trigger (13) Fig. 3. When the mechanism will not reject an oscillating groove record, either the screws mentioned in paragraph 1 are loose or the trip dog trip trigger (13) Fig. 3 or springs (15) Fig. 3 are at fault. When it is found that these parts have become worn or weak, they should be replaced.

3. Spiral Groove Records

Records with spiral reject grooves are rejected by the trip shoe (14) Fig. 3 located on the end of the tone arm lever (12) Fig. 3. This trip shoe (14) Fig. 3 hits the pin on the trip trigger (13) Fig. 3 releasing the clutch throwout bracket (29) Fig. 3. This should occur when the pick-up needle has traveled to within a distance of $\frac{1}{8}$ " from the center of the turntable spindle. Adjust the mechanism to properly reject this type of record as follows: If the pick-up does not reject the mechanism after traveling to within $\frac{1}{8}$ " from the center of the turntable spindle (or $\frac{1}{4}$ " from the edge of spindle), loosen the knurled nut holding trip shoe (14) Fig. 3 to the tone arm lever (12) Fig. 3. Move trip shoe toward or away from the pin on the trip trigger (13) Fig. 3 until the trip shoe operates the mechanism properly. When this point is found, the knurled nut should be well tightened.

TEN AND TWELVE INCH RECORDS DO NOT SEPARATE PROPERLY IN A MIXED LOADING

Ten and twelve inch records in a mixed loading are separated by lifter cams (20) Fig. 1 located on the record support arms (6) (16) Fig. 1. These cams operate when the next record to be selected by the mechanism is 10" and are designed to lift a 12" record when one is located directly above the 10" record. This allows the selector blades (5) Fig. 1 and guide arms (4) Fig. 1 to slide under the 12" record so that a 10" record can be placed on the turntable. The lifter cams (20) Fig. 1 are caused to operate by the 10" record hitting the end of the cam. Check the following parts when mechanism does not separate records properly:

1. The lifter cam link (20) Fig. 1 should be approximately $\frac{3}{32}$ " above the surface of the record support arms (6) (16) Fig. 1 when no records are on support arms (6) (16) Fig. 1. This link is held in this position by the small return spring found under (20) Fig. 1 underneath the support arms (6) (16) Fig. 1. If link is not above the surface of support arms (6) (16) Fig. 1, check for loose spring; replace spring if necessary.
2. The selector blades (5) Fig. 1 should have a slight downward pressure on the top surface of the guide arms (4) Fig. 1 when in their return position ready for next selection.
3. In their full return position after a record has been placed on the turntable the selector blades should also pass the guide arm link pin (22) Fig. 1 so that the selector blades will carry the guide arm toward the edge of a record when making the next selection. If any one of the blades do not return enough to clear the guide arm link pin (22) Fig. 1, the blade should be adjusted as given in paragraph "RECORD SELECTORS DO NOT OPERATE IN SYNCHRONISM".

INTER-MIX AUTOMATIC RECORD CHANGER---Part No. 35-1176

4. There should also be sufficient tension between the guide arm link pin (22) Fig. 1 and the end of the selector blade (5) Fig. 1 so that the guide arms (4) Fig. 1 will be pulled forward against the record when the selector blade (5) Fig. 1 moves to select the next record. Tension between guide arms and selector blades should be sufficient so that sloop on guide should lift a full load of records to proper height for selector blades to select bottom record. If guide arm pin (22) Fig. 1 does not have enough tension against end of selector blades (5) Fig. 1, check the springs holding the pin in position, also, for worn surface on side of pin.

5. Action of the selector guide arm (4) Fig. 1. The guide arm is designed to guide the selector blade (5) Fig. 1 and lift the record to the proper height necessary to separate the records. The top of the guide arm (4) Fig. 1 has two inclined surfaces. The outer surface for 10" records and the inner surface for 12" records. After the selector blades (5) Fig. 1 have entered between the records, the guide arm (4) Fig. 1 is released and returned to its normal position. If it does not return to its normal position, check for a weak spring on the guide arms (4) Fig. 1 or binding between guide arm and record support post (2) Fig. 1. These springs are attached to record support posts (2) (12) Fig. 1 and a pin at the swivel of the guide arm.

6. In case of a warped 10" record with its concave face down, resting on a warped 12" record with the concave face upward, there is a tendency for the selector blades to jam against the edge of the 10" record instead of going in under it. In order to prevent this condition the blades must be bent down sufficiently to slide along the top surface of the 12" record.

SELECTOR BLADE (5) FIG. 1 FAILS TO SEPARATE BOTTOM RECORD FROM STACK

This is due either to a badly warped condition of the record, or to its being of a thickness considerably different from those now in standard use. The design of both selector blade and record support arms is such as to accommodate a maximum variation in thickness and flatness of records, but certain records may be found which are so far out as to be unfit for use in the automatic changer.

RECORD SELECTORS DO NOT OPERATE IN SYNCHRONISM

If the record selector blades (5) Fig. 1 do not operate in synchronism proceed as follows:

1. Set the control knob (1) Fig. 2 to "automatic" position. See page 1 "Automatic and Manual Positions". (Turn knob to the left until it snaps up). Place one 10" record on selector blades. After record has been dropped to record supports, pull lower plug and rotate turntable by hand until the selector blades are close to the edge of record. At this point all selector blades should be as nearly as possible the same distance from spindle. If the selector blades are not the same distance from the spindle due to replacement of gears, etc., the blades are resynchronized as follows:

2. With the mechanism in the same condition as outlined in paragraph 1, remove the "C" washer from segment arms (23) or (27) Fig. 3 depending on which of these selector blades are out of time. Pull segment arm down so that gears are disengaged, then move selector blade (5) Fig. 1 in direction necessary to align it with other blades. When this position is found, mesh gears and replace "C" washer.

MECHANISM DOES NOT RETURN SELECTOR BLADES TO LOADING POSITION

If the selector blades will not return to the loading position (pointed toward spindle) after a record has been placed on the turntable:

1. Look for trouble in the parallel cam switch (6) Fig. 3. The contact of this switch should be in a closed position, at the time a record is being played.

2. When the selector blades are in the proper loading position cam (37) Fig. 3 should open parallel switch (6) Fig. 3. To place the mechanism in the loading position, turn changer switch (8) Fig. 1 off. After the switch is off the changer should continue to operate until the next record is selected and dropped on the turntable. When the record is dropped on the turntable, cam (37) Fig. 3 should open parallel switch (6) Fig. 3. When the turntable stops rotating the selector blades should be pointed toward spindle.

3. To adjust cam (37) Fig. 3 loosen the two set screws and rotate cam on the shaft until proper position is obtained. Retighten set screws.

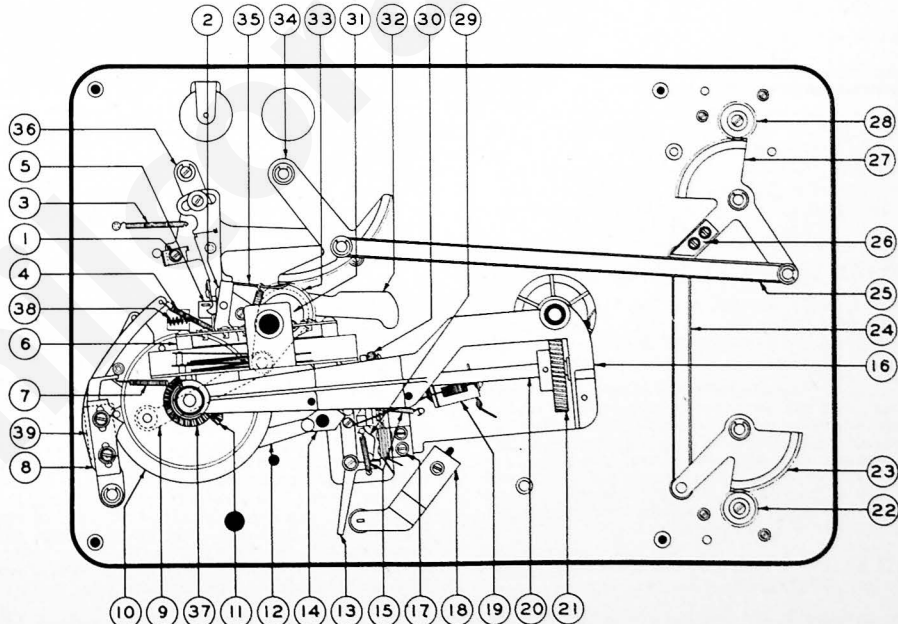

BOTTOM VIEW OF RECORD CHANGER PART No. 35-1176

FIGURE 3

NO REPRODUCTION WHEN NEEDLE IS OPERATING ON RECORD

A muting switch (177 Fig. 3, the purpose of which is to short the pick-up during the change cycle. This switch is mounted on the transmission frame, and is operated from the clutch throw-out (29) Fig. 3. When a record is on the turntable and the needle is in playing position, the contact of this switch should be in the open position.

AUTOMATIC CLUTCH DOES NOT COMPLETELY DISENGAGE AT THE END OF THE CYCLE

This trouble is identified by a steady thumping or clicking sound when the pick-up is in the playing position and is caused by the clutch not properly disengaging at the end of the automatic cycle. In most cases, this trouble is due to the clutch clearance adjusting plate not being in the proper position on the tone arm brake (8) Fig. 3. To eliminate this trouble, make the following adjustments:

1. Loosen the two screws that hold the clutch clearance adjusting plate to the tone arm brake lever (8) Fig. 3. Advance the adjusting plate until the clutch pawl [found in clutch housing (30) Fig. 3] clears the clutch sprocket.
2. If the clutch disengages before the pin on the drive drum (10) Fig. 3 reaches the inclined surface of the adjusting plate, the plate should then be retarded until the drive drum pin passes over the humps and slides down inclined surface.

FAILURE OF UNIVERSAL DRIVE COUPLING

The Universal drive coupling consists of four strips of rubber held together by a frame having ears projecting into slots in the rubber.

If excessive strain is placed on the coupling, the projecting ears may slip out of the slots in the rubber, thus disconnecting the drive. In order to hold the coupling together more firmly, the outer end of these ears projecting through the rubber may be bent outward at right angles to form a hook which will hold the rubber firmly in place. Do not make bend any more than $\frac{1}{8}$ " from end of ear. See Fig. 4.

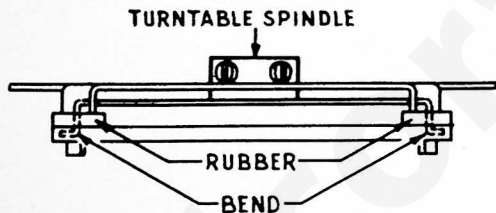

FIGURE 4

REMOVING MOTOR TRANSMISSION

In removing the motor transmission, the following parts should be disassembled first:

1. Remove turntable shaft. (See paragraph — Removing Turntable Shaft Assembly.)
2. Unsolder pick-up wires.
3. Loosen the two set screws which hold the tone arm lever and the tone arm shaft and remove tone arm and shaft.
4. Remove the mounting screws which hold the tone arm post to the panel. Unsolder electric tone arm reject switch wire from the terminal strip and remove tone arm post.
5. Remove "C" washer from the drive link pin — this will allow the drive link to be removed from the transmission and then remove the six mounting screws holding the transmission to the panel and take out the transmission.

TOP RECORD SLIPS WHEN PICK-UP IS IN THE PLAYING POSITION

If the top record slips in the playing position, check the following parts:

1. Check for excessively warped records. Records warped too badly should be replaced and not used in the changes.

2. Check for worn grooves in record, particularly old records. After the grooves of the records lose their gloss, the pick-up does not glide through the groove. This condition has a tendency to cause pick-up needle to drag resulting in the top record slipping.

3. Check record friction spring (16) Fig. 2 for tension. This spring should protrude far enough from the shaft to hold the top record from slipping when in the playing position. This spring when adjusted properly to hold a record, should also allow a 10" record to fall freely onto the turntable.

If the spring is in need of adjustment, see heading "Removing Turntable Shaft Assembly", Paragraph 4.

OILING AND GREASING MOTOR AND MECHANISM

The motor and mechanism should be oiled and greased every six months with a good grade of S. A. E. 10 oil.

Parts to Lubricate:

1. All bearings of the mechanism.
2. All sliding surfaces such as, cams, etc., should be lubricated with a very light grease.
3. Motor bearings and governor felt.

TURNTABLE SPEED ADJUSTMENT

If motor runs too fast or slow, the governor adjustment screw (27) Fig. 2 on the top side of the governor should be screwed in or out slightly as required. To do this, loosen the lock nut and turn screw, then retighten lock nut.

REMOVING TURNTABLE SHAFT ASSEMBLY

To remove the turntable shaft assembly, proceed as follows:

1. Loosen the two set screws holding the motor coupling (21) Fig. 2 to the turntable shaft.
2. Loosen the two screws holding the turntable drive worm (23) Fig. 2 to the turntable shaft, then lift out turntable and shaft.
3. To remove the turntable from the shaft, remove the three screws and nuts which hold it to the hub.
4. The record friction spring (16) Fig. 2 on the turntable shaft can be removed by pushing the hub downward toward the heavy end of the shaft — the spring can then be removed. If it is desired to increase the record friction on spring, bend upward the lower section of the spring which contacts with the bottom surface of the hub. To decrease the record friction against the spring, bend the spring downward.

The motor is removed as follows:

1. Remove the three $\frac{1}{8}$ " machine screws which hold the motor to the motor mounting bracket. Three $\frac{1}{2}$ " spurs will also be found which space the motor from the mounting plate.
2. There are two motor bracket locating pins on the underside of the changer base panel which pass through rubber grommets located in the motor mounting bracket. These are provided to keep the mounting panel and motor bracket in proper alignment.

MECHANISM AND CHASSIS MOUNTING

The mechanism is mounted in the cabinet as follows: 4 mounting studs are located in the bottom surface of the panel each threaded to take $\frac{1}{4}$ " No. 20 machine screws. The mounting panel rests on four tapered coil springs. The small end of each spring is pressed over a mounting stud and the large end of each spring fits into a screw in the top surface of the mounting shaft in the cabinet. Four spacing blocks $\frac{1}{2}$ " thick and with a $\frac{5}{8}$ " hole are fastened to the lower side of the cabinet motor board. The $\frac{5}{8}$ " hole in each block is centered with the $\frac{3}{16}$ " screw clearance hole. These are provided and located on the lower side of the cabinet motor board into which each of the lower mounting springs are to fit. The $\frac{1}{4}$ " No. 20 machine screws are turned through the four wing nuts until the head of each screw is against the head of the bottom side of each wing nut. The four lower springs are of smaller diameter than the upper springs. These lower springs are slipped over the nuts to each of the $\frac{1}{4}$ " No. 20 machine screws with the smaller end toward the head and resting on the wing nuts.

The $\frac{1}{4}$ " No. 20 machine screws are pushed through the $\frac{3}{16}$ " clearance hole and tightly screwed into the mounting studs. Wing nuts should be backed down on head of $\frac{1}{4}$ " No. 20 bolt to place changer in operation.